

B-747-200F

Freighter (Nose Door)

Range: 3,500 nm/6,640 km.

Volume: 25,591 cf/724.7 cm.

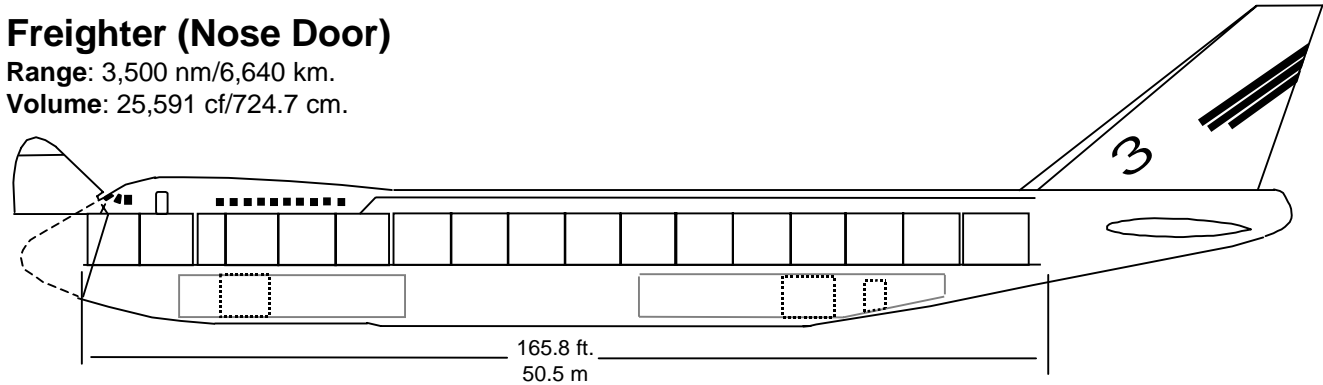

Main Deck 29 Pallets (96 in. x 125 in.) and 2 Half Pallets (96 in. x 53 in.)

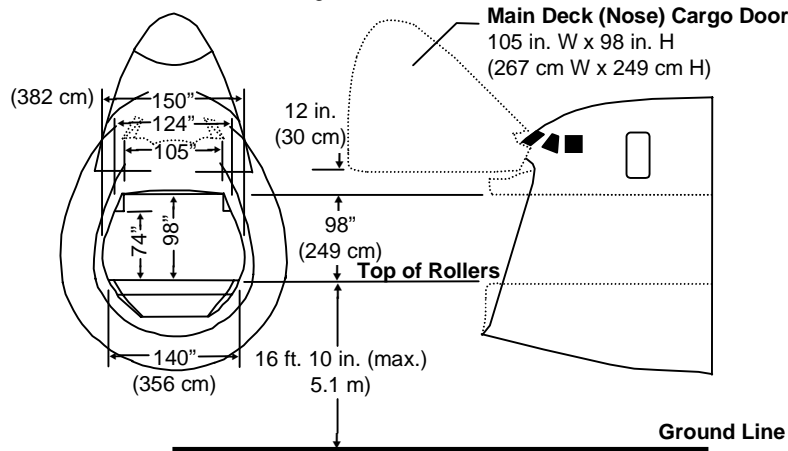
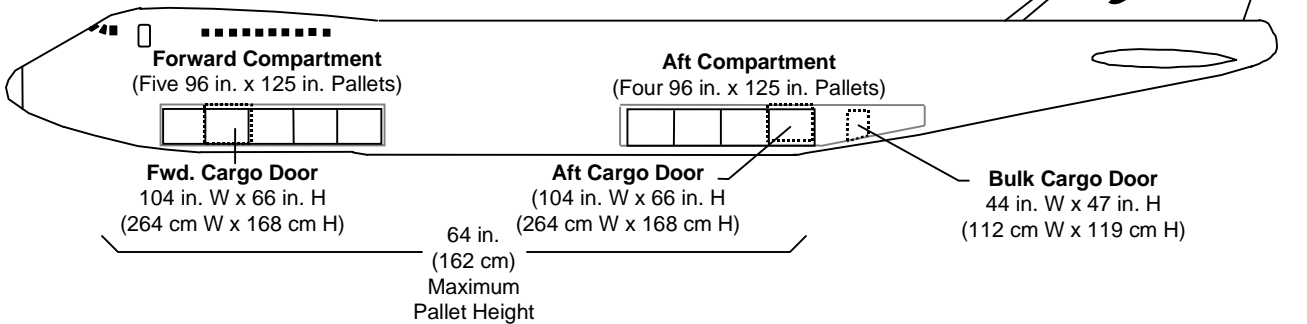
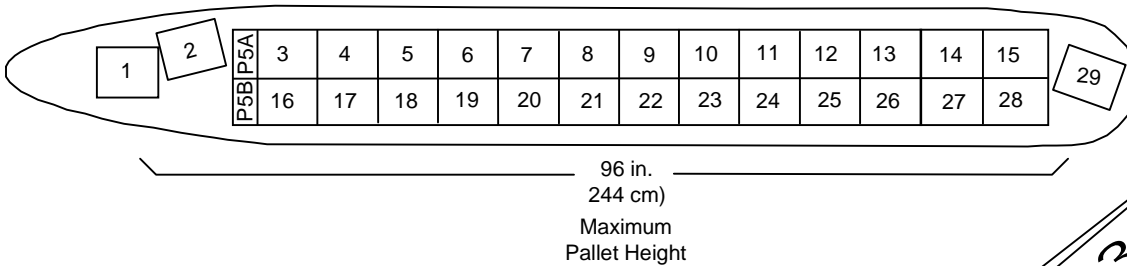

Pallet Position Max. Weights*

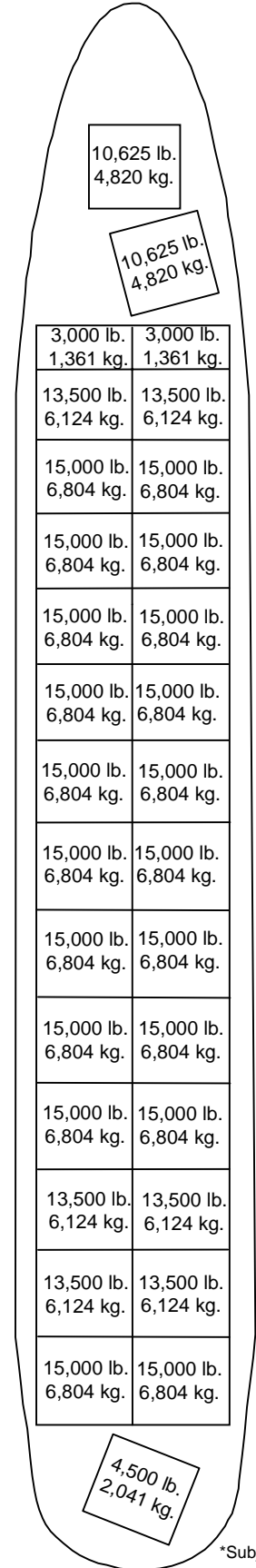

**Lower Deck
Max. Weights***
(96 in. x 125 in.
Pallets)

10,625 lb.
4,820 kg.

10,625 lb.
4,820 kg.

3,000 lb. 3,000 lb.
1,361 kg. 1,361 kg.

13,500 lb. 13,500 lb.
6,124 kg. 6,124 kg.

15,000 lb. 15,000 lb.
6,804 kg. 6,804 kg.

15,000 lb. 15,000 lb.
6,804 kg. 6,804 kg.

15,000 lb. 15,000 lb.
6,804 kg. 6,804 kg.

15,000 lb. 15,000 lb.
6,804 kg. 6,804 kg.

15,000 lb. 15,000 lb.
6,804 kg. 6,804 kg.

15,000 lb. 15,000 lb.
6,804 kg. 6,804 kg.

15,000 lb. 15,000 lb.
6,804 kg. 6,804 kg.

15,000 lb. 15,000 lb.
6,804 kg. 6,804 kg.

15,000 lb. 15,000 lb.
6,804 kg. 6,804 kg.

15,000 lb. 15,000 lb.
6,804 kg. 6,804 kg.

13,500 lb. 13,500 lb.
6,124 kg. 6,124 kg.

13,500 lb. 13,500 lb.
6,124 kg. 6,124 kg.

15,000 lb. 15,000 lb.
6,804 kg. 6,804 kg.

4,500 lb.
2,041 kg.

11,100 lb.
5,035 kg.

11,100 lb.
5,035 kg.

11,100 lb.
5,035 kg.

11,100 lb.
5,035 kg.

11,100 lb.
5,035 kg.

11,100 lb.
5,035 kg.

11,100 lb.
5,035 kg.

11,100 lb.
5,035 kg.

11,100 lb.
5,035 kg.

14,800 lb.
6,750 kg.
(bulk)

B-747-200F

Freighter (Nose Door)

N470EV, N471EV

Max. Gross Payload: 245,700 lbs/109,000 kgs.

**Nose Door
Max. Piece Size**
(Length of Main Deck
Apx. 175 ft./53.3 m)

Height Inches	Width Inches
Upright Loading	
96	106
90	108
80	113
70	132
60	140
50	143
40	145
30	147
20	148
Tilted Loading	
12	148
8	151
4	154

Lower Deck Max. Piece Size
Forward & Rear Compartments

Height Inches	Width in Inches											
	10	20	30	40	50	60	70	80	90	100	104	
	Length in Inches											
64	280	245	220	195	170	155	125	125	125	125	125	125
60	330	285	240	220	195	175	160	145	135	125	125	125
55	385	325	280	245	215	195	175	155	145	135	135	135
50	440	360	305	265	230	210	185	165	150	145	140	140
45	440	430	360	300	260	225	200	170	155	150	140	140
40	440	440	410	345	290	255	220	195	175	160	155	155
35	440	440	440	380	330	270	235	205	180	160	155	155
30	440	440	440	420	345	285	245	210	190	165	160	160
25	440	440	440	440	360	300	255	220	190	165	160	160
20	440	440	440	440	385	315	265	225	195	170	160	160
15	440	440	440	440	415	330	280	235	200	175	160	160
10	440	440	440	440	440	360	295	245	210	180	165	165
5	440	440	440	440	440	440	320	265	225	185	170	170

Aft Bulk Compartments

Height Inches	Width in Inches										
	4	8	12	16	20	24	28	32	36	40	44
	Length in Inches										
47	140	140	140	132	126	126	126	126	126	126	126
43	160	160	160	160	150	150	145	135	135	130	130
39	185	185	185	165	155	150	145	140	135	135	130
35	205	205	205	180	165	155	150	145	140	135	130
32	210	210	210	205	185	175	160	155	150	145	130
28	225	225	225	225	210	175	165	155	150	145	130
24	235	235	235	235	210	175	165	155	150	145	130
4-19	235	235	235	235	235	225	205	175	165	155	150

EVERGREEN INTERNATIONAL AIRLINES, INC.

Headquarters

3850 Three Mile Lane • McMinnville, Oregon 97128-9496 USA
Tel: 503-472-0011 • Toll Free: 800-382-2746 • Fax: 503-434-4210
E-mail: easales@evergreenaviation.com • SITA: HDQSSEZ

*Subject to weight and balance limitations